

# Container Holder Kit

for use with the AP550e Label Applicator



## Instruction Manual

# AP550e

## LABEL APPLICATOR

© 2019 All rights reserved.

For the most recent version of this manual please

visit [dtm-print.eu](http://dtm-print.eu)

The AP550e Container Holder Kit can be used to securely hold any size container in a consistent position on the Container Platform. This ensures accurate labeling. This kit is highly recommended for any odd-shaped container or any small container that would be difficult to hold in place during labeling without interference from the Application Arm. The Kit comes in “small tray” and “large tray” versions. The following parts are included in the kits:



Press & Mold Molding Compound

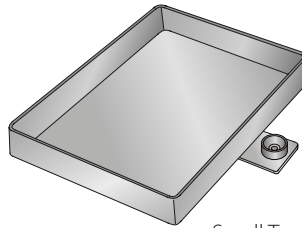

Small Tray - 15 x 20 cm  
(#74398 includes 2 Small Trays)

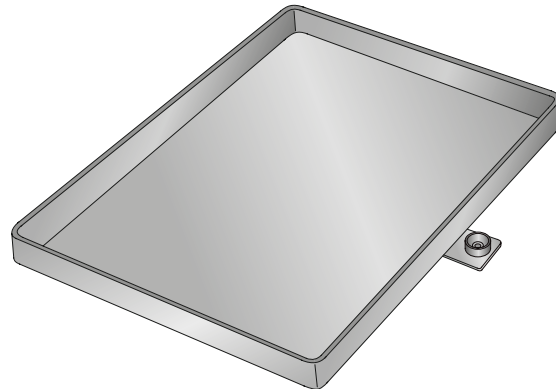

Large Tray - 25.4 x 30.4 cm  
(#74399 includes 2 Large Trays)

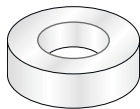

UHMW Tape

## Section 1: Prepare the Container

To account for shrinkage of the molding compound and for subtle variations from container-to-container, you must put a layer of the included UHMW Tape over the portion of the container that will come in contact with the molding compound. This tape also allows the container to easily release from the molding compound.

Apply the tape to the container without overlapping the tape.

It may be necessary to cut the tape to fit the container using a utility knife.

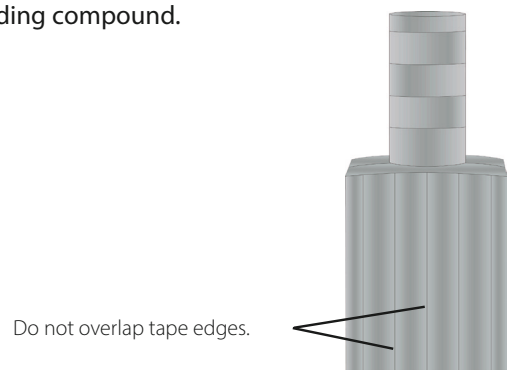

Example Container

## Section 2: Prepare the Tray

1. Choose the appropriate size tray for your container.
2. Fill the tray completely full with the Press & Mold Molding Compound.
3. Place the tray in an oven. Set the oven temperature to 65°C. Do not microwave!
4. Bake at this temperature for up to 2 hours or until the molding compound pellets have melted together and turned clear. Periodically check the pellets during the first two hours.
5. Due to oven temperature variations, you may need to bake the pellets longer. If after two hours the pellets have not turned clear, increase the oven temperature by 16°C. Check the pellets every 10 minutes until they have turned clear.

**WARNING!** For your safety as well as the proper functionality of this product, do NOT heat to more than 71°C. Serious burns or other injuries can be caused by higher temperatures.

## Section 3: Create the Mold

1. Using oven mitts, remove the tray from the oven and place it on a wood or metal cooling rack with holes or spaces to accommodate the pins on the bottom of the tray. Caution! The tray will be hot!
2. Place the UHMW tape-covered container tape side down in the molding compound. Note the orientation of the labels coming off the roll and position your container accordingly.
3. Firmly press down on your container so that it becomes imbedded in the mold. Align the container so that it is parallel with the tray edges.
4. The molding compound may push away from the container when you press it down. While holding the container in place, push the molding compound back against the container. You may touch the molding compound with your bare hands right out of the oven, but the tray itself will remain very hot for several minutes. If your container has indentations on any side, do not press the molding compound into these areas as it will make it difficult to place and remove containers for labeling. During the forming process make sure to keep the container parallel with the tray. The molding compound will remain workable for approximately 10 minutes.
5. Allow the molding compound to cool. The molding compound has "cooled" when it has turned completely white. This will take about an hour.
6. Remove the container from the molding compound. Make sure the compound has cooled before removing the container or the shape of your mold may become distorted.

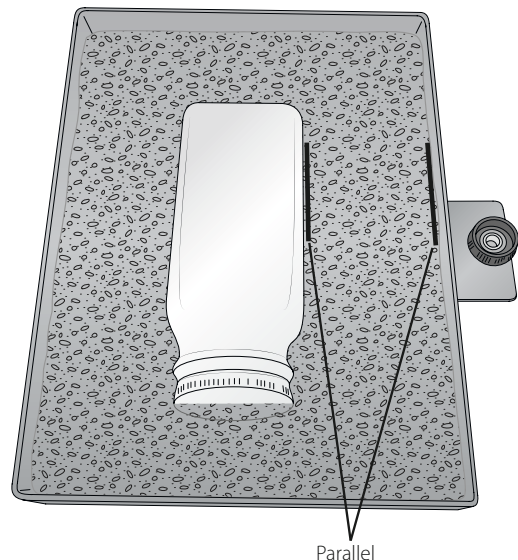

## Section 4: Place the Tray on the Applicator Platform

1. The tray has pins on the bottom that correspond to holes on the movable Container Guide attached to the AP550e Container Platform. Place the tray on the platform so the pins drop into the corresponding holes.
2. If the container does not sit square to the platform (labels will be applied crooked), adjust the angle of the tray. Loosen the thumb screw. Adjust the angle as needed. Retighten the thumb screw. You may also adjust the side-to-side position of the tray by following the instructions for adjusting the Container Guides in Section 3 of the AP550e Operator's Guide.

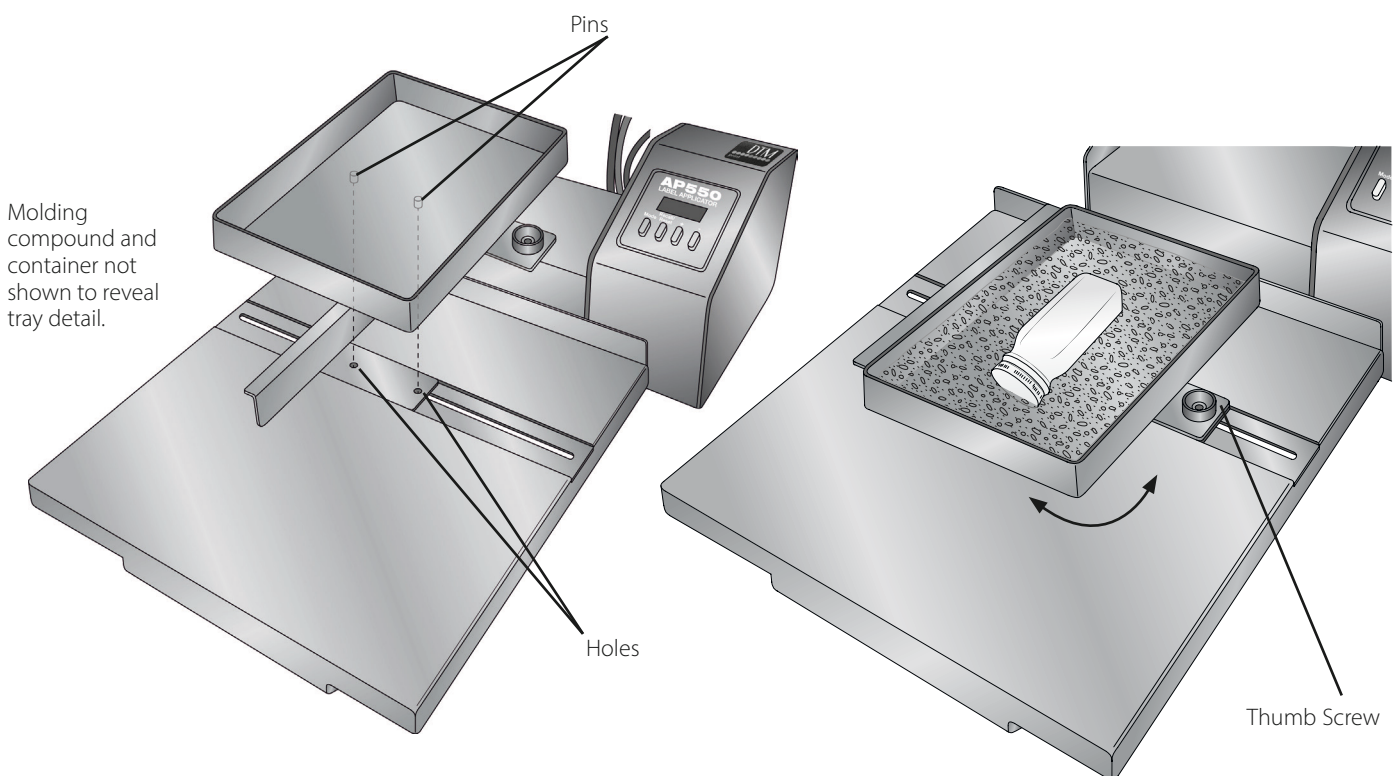

Congratulations! You are now ready to label your containers.